

W2 Optronics, Inc.

DPSK Demodulator

Specification

2011 Rev. F

PART NUMBER

DPSK-F-667

FSR=66.7GHz

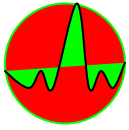

W2 Optronics, Inc.

CONTENT

1 Product Description and Diagram.....	3
2 Environment Conditions.....	3
3 Electro Optical Specifications.....	4
4 Mechanical Drawing	5
5 Appendix Channel plan.....	6

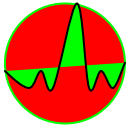

W2 Optronics, Inc.

Product Description and Diagram

40Gb/s DPSK Demodulator, also known as Delay Line Interferometer (DLI), converts phase modulation to amplitude modulation in support of data transmission rates of 10 or 40Gb/s. The DPSK Demodulator is designed for phase modulated optical communication systems utilized in optical networks. The DLI plays a key role in improving signal quality and performance to meet the expanding demand for higher data rates and more complex transmission formats within current and next generation systems without major capital expenditure.

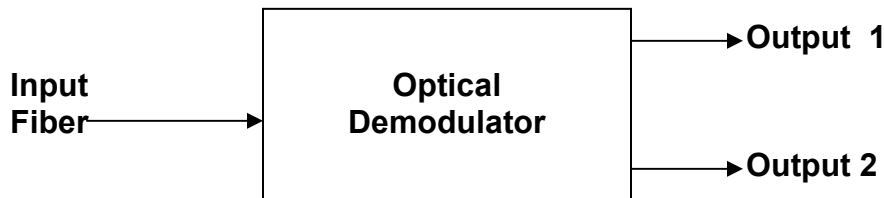

This document describes the optical, electrical and mechanical specifications for an optical demodulator for DPSK systems. The above figure shows the basic schematic of a single optical demodulator. The device is an all-pass filter with a free spectral range, FSR, and a variable optical phase shift.

Definitions of key parameters:

1. Insertion Loss: It is the polarization-averaged transmission loss measured through any one arm of the demodulator.
2. Free Spectral Range: It is the frequency shift between two consecutive peaks (or valleys) in the polarization-averaged transmission spectrum through one arm of the interferometer.
3. Extinction Ratio: It is the difference in dB between consecutive peaks and valleys in the polarization-averaged transmission spectrum through one arm of the interferometer.
4. Polarization Dependent Frequency Shift: It is the maximum frequency shift in the transmission spectrum induced by a change in the polarization of the input optical signal.

Environment Conditions

The module must be reliably endure the following conditions.

Item	Conditions	Unit	Specification		
			Min.	Typ.	Max.
1	Operating Temperature	C	-5	-	70
2	Storage Temperature	C	-40		85
3	Relative Humidity non condensing	%	5		95

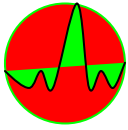

W2 Optonics, Inc.

Electro-Optical Specifications

The module meets the specifications over all polarization states and over the specified operating conditions.

Item	Parameter	Symbol	Unit	Specification		
				Min.	Typ.	Max.
1	Wavelength Range	λ	nm	1527	-	1567
2	Free Spectral Range	FSR	GHz	66.7		
3	FSR Error	Δ FSR	%	-1		+1
4	Insertion Loss	IL	dB		1.7	2.2
5	Insertion Loss Uniformity (IL on port 2 -IL of port 1)	Δ IL	dB			0.7
6	Extinction Ratio	ISO	dB	20		
7	Polarization Dependent Loss	PDL	dB			0.2
8	Return Loss	ORL	dB	40		
9	PMD	PMD	ps			0.1
10	Polarization Dependent Frequency Shift	PDFS	GHz			0.6
11	Temperature dependent Frequency shift	TDFS	GHz/C°			0.2
12	Optical Path Delay between two output ports	OPD	ps			1
13	Tuning Time Constant 0~50%	T	sec			1
14	Tuning Range	TR	FSR	1.5		3
15	Tuning Resistance	R	Ω	40		60
16	Power Consumption	PC	W			0.75
17	Tuning Voltage	V	V	0		5
18	Maximum input Optical Power	P	mW			300
19	Connector Type			LC/UPC		
20	Fiber Pigtail Type			SMF-28 or equivalent with 900um tube		
21	Fiber Length		m	1.0+/-0.1		

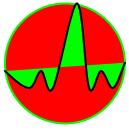

W2 Optronics, Inc.

Mechanical Drawing

The dimension for DPSK DLI is 9X25X25mm except fiber boot, package drawing is shown below.

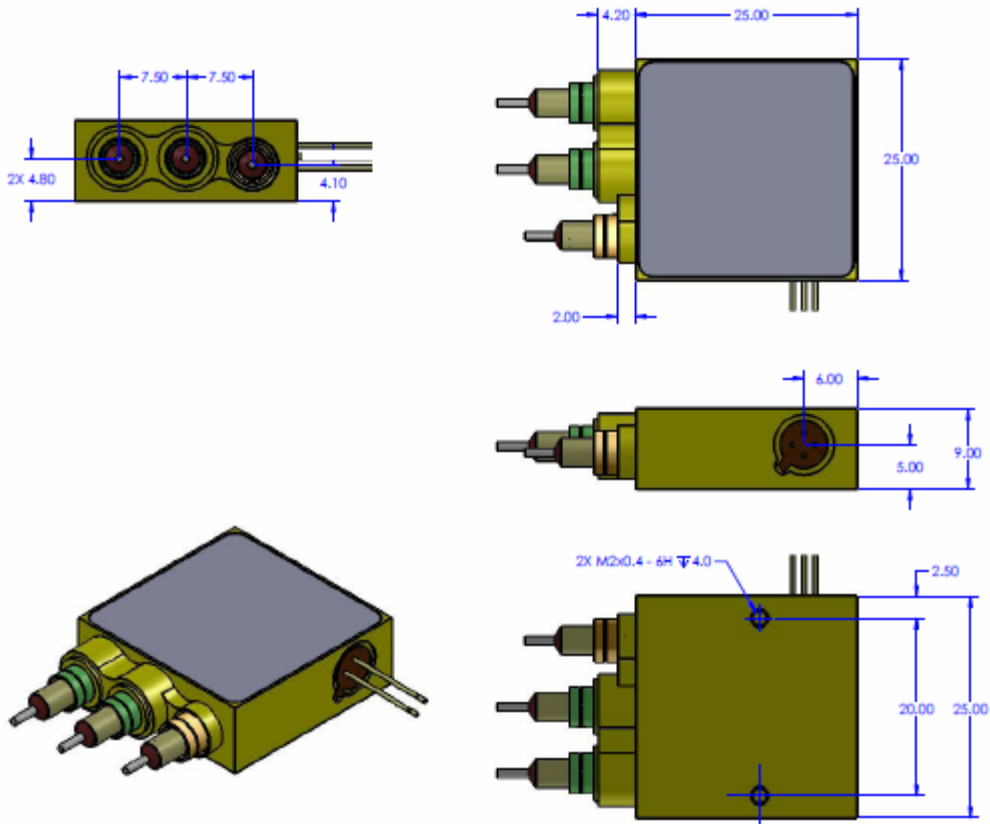

There are two Pins: One is GND, Another to apply 0~5V DC voltage to tune.

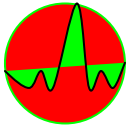

W2 Optronics, Inc.

Channel Plan

Central wavelength / frequency with 100GHz grid in C band (ITU-T G.692)

Central λ (nm)	Frequency (THz)	Central λ (nm)	Frequency (THz)
1528.77	196.10*	1548.51	193.60
1529.55	196.00	1549.32	193.50
1530.33	195.90	1550.12	193.40
1531.12	195.80	1550.92	193.30
1531.90	195.70	1551.72	193.20
1532.68	195.60	1552.52	193.10
1533.47	195.50	1553.33	193.00
1534.25	195.40	1554.13	192.90
1535.04	195.30	1554.94	192.80
1535.82	195.20	1555.75	192.70
1536.61	195.10	1556.55	192.60
1537.40	195.00	1557.36	192.50
1538.19	194.90	1558.17	192.40
1538.98	194.80	1558.98	192.30
1539.77	194.70	1559.79	192.20
1540.56	194.60	1560.61	192.10
1541.35	194.50	1561.42	192.00
1542.14	194.40	1562.23	191.90
1542.94	194.30	1563.05	191.80
1543.73	194.20	1563.86	191.70
1544.53	194.10	1564.68	191.60
1545.32	194.00	1565.50	191.50
1546.12	193.90	1566.31	191.40
1546.92	193.80	1567.13	191.30
1547.72	193.70	1567.95	191.20*

Central wavelength / frequency with 100GHz grid in C+ band (ITU-T G.692)

Central λ (nm)	Frequency (THz)	Central λ (nm)	Frequency (THz)
1529.16	196.05	1548.91	193.55
1529.94	195.95	1549.72	193.45
1530.72	195.85	1550.52	193.35
1531.51	195.75	1551.32	193.25
1532.29	195.65	1552.12	193.15
1533.07	195.55	1552.93	193.05
1533.86	195.45	1553.73	192.95
1534.64	195.35	1554.54	192.85
1535.43	195.25	1555.34	192.75
1536.22	195.15	1556.15	192.65
1537.00	195.05	1556.96	192.55
1537.79	194.95	1557.77	192.45
1538.58	194.85	1558.58	192.35
1539.37	194.75	1559.39	192.25
1540.16	194.65	1560.20	192.15
1540.95	194.55	1561.01	192.05
1541.75	194.45	1561.83	191.95
1542.54	194.35	1562.64	191.85
1543.33	194.25	1563.45	191.75
1544.13	194.15	1564.27	191.65
1544.92	194.05	1565.09	191.55
1545.72	193.95	1565.90	191.45
1546.52	193.85	1566.72	191.35
1547.32	193.75	1567.54	191.25*
1548.11	193.65	1568.36	191.15*